

FLOOR JOIST SPAN

Notes:

1. Spans are based on continuous lateral support of the compression flange.
2. Spans are based on $F_y = 33$ ksi.
3. For two equal spans, the listed span is the distance from either end support to the center support.
Joists must be continuous over the center support.
4. Spans noted with an "e" require web stiffeners at end supports.

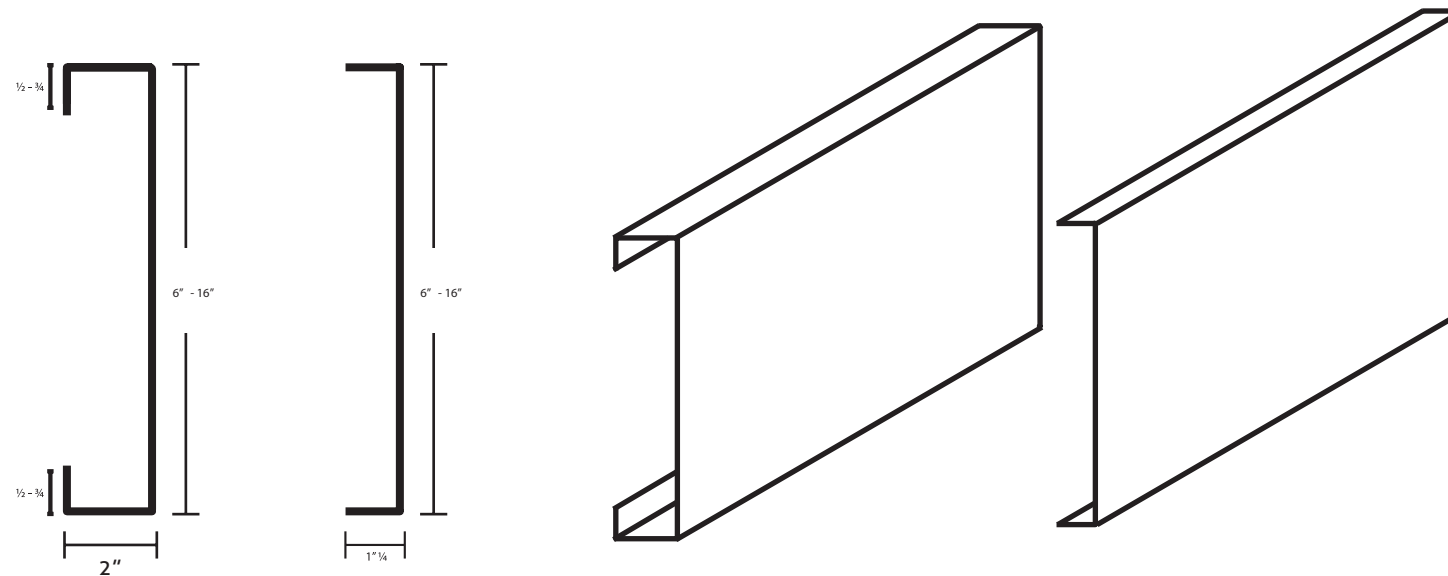

Web (in)	Gauge	Flange (in)	Lip (in)	10 psf Dead Load plus 40 PSF Live Load						10 psf Dead Load plus 60 PSF Live Load						40 psf Dead Load plus 40 PSF Live Load						40 psf Dead Load plus 60 PSF Live Load						15 psf Dead Load plus 125 PSF Live Load						40 psf Dead Load plus 125 PSF Live Load					
				L/360			L/480			L/360			L/480			L/360			L/480			L/360			L/480			L/360			L/480			L/360			L/480		
				SINGLE SPAN JOIST SPACING (IN.) O.C.			SINGLE SPAN JOIST SPACING (IN.) O.C.			SINGLE SPAN JOIST SPACING (IN.) O.C.			SINGLE SPAN JOIST SPACING (IN.) O.C.			SINGLE SPAN JOIST SPACING (IN.) O.C.			SINGLE SPAN JOIST SPACING (IN.) O.C.			SINGLE SPAN JOIST SPACING (IN.) O.C.			SINGLE SPAN JOIST SPACING (IN.) O.C.			SINGLE SPAN JOIST SPACING (IN.) O.C.			SINGLE SPAN JOIST SPACING (IN.) O.C.			SINGLE SPAN JOIST SPACING (IN.) O.C.					
			12	16	24	12	16	24	12	16	24	12	16	24	12	16	24	12	16	24	12	16	24	12	16	24	12	16	24	12	16	24	12	16	24	12	16	24	
6	16	2	0.5	13'2"e	11'5"e	9'4"e	13'10"	12'6"e	10'11"e	13'3"e	12'1"e	10'4"e	12'1"e	10'11"e	9'7"e	13'8"e	11'10"e	9'8"e	13'8"e	11'10"e	9'8"e	12'2"e	10'7"e	8'7"e	12'1"e	10'7"e	8'7"e	10'4"e	8'11"e	7'3"e	9'5"e	8'7"e	7'3"e	9'6"e	8'3"e	6'8"e	9'5"e	8'3"e	6'8"e
6	14	2	0.5	16'4"	14'10"	12'11"e	14'10"	13'5"	11'9"	14'3"	12'11"e	11'3"e	12'11"	11'9"	10'3"e	14'10"	13'5"e	10'11"e	14'10"	13'5"e	10'11"e	13'9"e	12'0"e	9'9"e	12'11"e	11'9"e	9'9"e	11'2"e	10'1"e	8'3"e	10'1"e	9'2"e	8'0"e	10'9"e	9'4"e	7'7"e	10'1"e	9'2"e	7'7"e
6	12	2	0.5	18'1"	16'5"	14'4"	16'5"	14'11"	13'0"	15'10"	14'4"	12'6"	14'4"	13'0"	11'5"	16'5"	14'11"	13'0"	16'5"	14'11"	13'0"	15'3"	13'10"	11'10"e	14'4"	13'0"	11'5"	12'4"	11'3"	9'10"e	11'3"	10'2"	8'11"e	12'4"	11'3"e	9'2"e	11'3"	10'2"	8'11"e
6	10	2	0.5	19'2"	17'5"	15'2"	17'5"	15'9"	13'9"	16'8"	15'2"	13'3"	15'2"	13'9"	12'0"	17'5"	15'9"	13'9"	17'5"	15'9"	13'9"	16'2"	14'8"	12'9"	15'2"	13'9"	12'0"	13'1"	11'10"	10'4"	11'10"	10'9"	9'5"	13'1"	11'10"	10'2"e	11'10"	10'9"	9'5"
6	16	2	0.625	15'4"	13'11"e	12'2"e	13'11"	12'8"e	11'0"e	13'5"e	12'2"e	10'7"e	12'2"e	11'0"e	9'8"e	13'11"e	12'3"e	10'0"e	13'11"e	12'3"e	10'0"e	12'8"e	10'11"e	8'11"e	12'2"e	10'11"e	8'11"e	10'6"e	9'3"e	7'6"e	9'6"e	8'8"e	7'6"e	9'10"e	8'6"e	6'11"e	9'6"e	8'6"e	6'11"e
6	14	2	0.625	16'5"	14'11"	13'1"e	14'11"	13'7"	11'10"	14'4"	13'1"e	11'5"e	13'1"	11'10"	10'4"e	14'11"	13'7"e	11'3"e	14'11"	13'7"e	11'3"e	13'10"e	12'3"e	10'0"e	13'1"e	11'10"e	10'0"e	11'3"e	10'2"e	8'6"e	10'2"e	9'3"e	8'1"e	11'1"e	9'7"e	7'10"e	10'2"e	9'3"e	7'10"e
6	12	2	0.625	18'3"	16'7"	14'6"	16'7"	15'1"	13'2"	15'11"	14'6"	12'8"	14'6"	13'2"	11'6"	16'7"	15'1"	13'2"	16'7"	15'1"	13'2"	15'5"	14'0"	12'0"e	14'6"	13'2"	11'6"	12'6"	11'4"	9'11"e	11'4"	10'4"	9'0"e	12'6"	11'4"e	9'4"e	11'4"	10'4"	9'0"e
6	10	2	0.625	19'4"	17'6"	15'4"	17'6"	15'11"	13'11"	16'10"	15'4"	13'5"	15'4"	13'11"	12'2"	17'6"	15'11"	13'11"	17'6"	15'11"	13'11"	16'3"	14'9"	12'11"	15'4"	13'11"	12'2"	13'2"	12'0"	10'6"	12'0"	10'11"	9'6"	13'2"	12'0"	10'4"	12'0"	10'11"	9'6"
8	16	2	0.5	19'1"e	17'4"e	14'11"e	17'4"e	15'9"e	13'9"e	16'8"e	15'2"e	12'7"e	15'2"e	13'9"e	12'0"e	16'8"e	14'5"e	11'9"e	16'8"e	14'5"e	11'9"e	14'11"e	12'11"e	10'6"e	14'11"e	12'11"e	10'6"e	12'7"e	10'11"e	8'11"e	11'10"e	10'9"e	8'11"e	11'7"e	10'0"e	8'2"e	11'7"e	10'0"e	8'2"e
8	14	2	0.5	20'6"	18'7"e	16'3"	18'7"	16'11"	14'9"e	17'11"e	16'3"e	14'2"e	16'3"	14'9"e	12'11"e	18'7"e	16'5"e	13'4"e	18'7"e	16'5"e	13'4"e	16'11"e	14'8"e	11'11"e	16'3"e	14'8"e	11'11"e	14'0"e	12'4"e	10'1"e	12'9"e	11'7"e	10'1"e	13'2"e	11'5"e	9'4"e	12'9"e	11'5"e	9'4"e
8	12	2	0.5	22'10"	20'9"	18'1"	20'9"	18'10"	16'5"	19'11"	18'1"	15'10"	18'1"	16'5"	14'4"	20'9"	18'10"	16'3"e	20'9"	18'10"	16'3"e	19'3"	17'6"e	14'6"e	18'1"	16'5"	14'4"	15'7"	14'2"e	12'3"e	14'2"	12'10"e	11'3"e	15'7"e	13'10"e	11'3"e	14'2"e	12'10"e	11'3"e
8	10	2	0.5	24'2"	21'11"	19'2"	21'11"	19'11"	17'5"	21'1"	19'2"	16'9"	19'2"	17'5"	15'2"	21'11"	19'11"	17'5"	21'11"	19'11"	17'5"	20'4"	18'6"	16'0"	19'2"	17'5"	15'2"	16'6"	15'0"	13'1"e	15'0"	13'7"	11'11"e	16'6"	15'0"e	12'6"e	15'0"	13'7"	11'11"e
8	16	2	0.625	19'3"e	17'6"e	15'3"e	17'6"e	15'11"e	13'10"e	16'10"e	15'3"e	13'0"e	15'3"e	13'10"e	12'1"e	17'3"e	14'11"e	12'2"e	17'3"e	14'11"e	12'2"e	15'5"e	13'4"e	10'10"e	15'3"e	13'4"e	10'10"e	13'0"e	11'3"e	9'2"e	11'11"e	10'10"e	9'2"e	12'0"e	10'4"e	8'5"e	11'11"e	10'4"e	8'5"e
8	14	2	0.625	20'8"	18'9"e	16'5"e	18'9"	17'1"	14'11"e	18'1"e	16'5"e	14'4"e	16'5"	14'11"e	13'0"e	18'9"e	16'9"e	13'8"e	18'9"e	16'9"e	13'8"e	17'4"e	15'0"e	12'3"e	16'5"e	14'11"e	12'3"e	14'2"e	12'8"e	10'4"e	12'10"e	11'8"e	10'2"e	13'6"e	11'8"e	9'6"e	12'10"e	11'8"e	9'6"e
8	12	2	0.625	23'0"	20'11"	18'3"	20'11"	19'0"	16'7"	20'1"	18'3"	15'11"	18'3"	16'7"	14'6"	20'11"	19'0"	16'5"e	20'11"	19'0"	16'5"e	19'5"	17'7"e	14'8"e	18'3"	16'7"	14'6"e	15'9"	14'3"e	12'5"e	14'3"	13'0"e	11'4"e	15'9"e	14'0"e	11'5"e	14'3"e	13'0"e	11'4"e
8	10	2	0.625	24'4"	22'2"	19'4"	22'2"	20'1"	17'7"	21'3"	19'4"	16'11"	19'4"	17'7"	15'4"	22'2"	20'1"	17'7"	22'2"	20'1"	17'7"	20'6"	18'8"	16'3"e	19'4"	17'7"	15'4"	16'8"	15'1"	13'2"e	15'1"	13'9"	12'0"e	16'8"	15'1"e	12'8"e	15'1"	13'9"	12'0"e

FLOOR JOIST SPAN (Cont.)

				10 psf Dead Load plus 40 PSF Live Load						10 psf Dead Load plus 60 PSF Live Load						40 psf Dead Load plus 40 PSF Live Load						40 psf Dead Load plus 60 PSF Live Load						15 psf Dead Load plus 125 PSF Live Load						40 psf Dead Load plus 125 PSF Live Load					
				L/360			L/480			L/360			L/480			L/360			L/480			L/360			L/480			L/360			L/480								
Web (in)	Gauge	Flange (in)	Lip (in)	SINGLE SPAN JOIST SPACING (IN.) O.C.			SINGLE SPAN JOIST SPACING (IN.) O.C.			SINGLE SPAN JOIST SPACING (IN.) O.C.			SINGLE SPAN JOIST SPACING (IN.) O.C.			SINGLE SPAN JOIST SPACING (IN.) O.C.			SINGLE SPAN JOIST SPACING (IN.) O.C.			SINGLE SPAN JOIST SPACING (IN.) O.C.			SINGLE SPAN JOIST SPACING (IN.) O.C.			SINGLE SPAN JOIST SPACING (IN.) O.C.											
				12	16	24	12	16	24	12	16	24	12	16	24	12	16	24	12	16	24	12	16	24	12	16	24	12	16	24	12	16	24						
10	16	2	0.5	22'1"	19'1"	15'7"	20'7"	18'6"	15'7"	18'8"	16'2"	13'2"	18'0"	16'2"	13'2"	17'5"	15'1"	12'4"	17'5"	15'1"	12'4"	15'7"	13'6"	11'0"	15'7"	13'6"	11'0"	13'2"	11'5"	9'4"	13'2"	11'5"	9'4"	12'2"	10'6"	8'7"	12'2"	10'6"	8'7"
10	14	2	0.5	24'6"	22'3"	18'2"	22'3"	20'3"	17'8"	21'5"	18'10"	15'4"	19'6"	17'8"	15'4"	20'4"	17'7"	14'5"	20'4"	17'7"	14'5"	18'2"	15'9"	12'10"	18'2"	15'9"	12'10"	15'4"	13'4"	10'10"	15'3"	13'4"	10'10"	14'2"	12'3"	10'0"	14'2"	12'3"	10'0"
10	12	2	0.5	27'4"	24'10"	21'9"	24'10"	22'7"	19'9"	23'11"	21'9"	18'9"	21'9"	19'9"	17'3"	24'10"	21'6"	17'7"	24'10"	21'6"	17'7"	22'3"	19'3"	15'9"	21'9"	19'3"	15'9"	18'8"	16'3"	13'3"	17'0"	15'5"	13'3"	17'4"	15'0"	12'3"	17'0"	15'0"	12'3"
10	10	2	0.5	29'0"	26'4"	23'0"	26'4"	23'11"	20'11"	25'4"	23'0"	20'1"	23'0"	20'11"	18'3"	26'4"	23'11"	20'11"	26'4"	23'11"	20'11"	24'5"	22'3"	18'11"	23'0"	20'11"	18'3"	19'10"	18'0"	15'9"	18'0"	16'4"	14'3"	19'10"	19'0"	14'8"	18'0"	16'4"	14'3"
10	16	2	0.625	22'10"	19'9"	16'1"	20'9"	18'10"	16'1"	19'3"	16'8"	13'7"	18'1"	16'5"	13'7"	18'0"	15'7"	12'9"	18'0"	15'7"	12'9"	16'1"	14'0"	11'5"	16'1"	14'0"	11'5"	13'7"	11'9"	9'7"	13'7"	11'9"	9'7"	12'7"	10'10"	8'10"	12'7"	10'10"	8'10"
10	14	2	0.625	24'9"	22'6"	18'6"	22'6"	20'5"	17'10"	21'7"	19'2"	15'7"	19'7"	17'10"	15'7"	20'8"	17'11"	14'7"	20'8"	17'11"	14'7"	18'6"	16'0"	13'1"	18'6"	16'0"	13'1"	15'7"	13'6"	11'0"	15'4"	13'6"	11'0"	14'5"	12'5"	10'2"	14'5"	12'5"	10'2"
10	12	2	0.625	27'7"	25'1"	21'11"	25'1"	22'9"	19'11"	24'1"	21'11"	19'0"	21'11"	19'11"	17'4"	25'1"	21'10"	17'10"	25'1"	21'10"	17'10"	22'6"	19'6"	15'11"	21'11"	19'6"	15'11"	18'10"	16'6"	13'5"	17'2"	15'7"	13'5"	17'6"	15'2"	12'5"	17'2"	15'2"	12'5"
10	10	2	0.625	29'3"	26'7"	23'3"	26'7"	24'2"	21'1"	25'7"	23'3"	20'3"	23'3"	21'1"	18'5"	26'7"	24'2"	21'1"	26'7"	24'2"	21'1"	24'8"	22'5"	19'2"	23'3"	21'1"	18'5"	20'0"	18'2"	15'10"	18'2"	16'6"	14'5"	20'0"	18'2"	14'11"	18'2"	16'6"	14'5"

				10 psf Dead Load plus 40 PSF Live Load						10 psf Dead Load plus 60 PSF Live Load						40 psf Dead Load plus 40 PSF Live Load						40 psf Dead Load plus 60 PSF Live Load						15 psf Dead Load plus 125 PSF Live Load						40 psf Dead Load plus 125 PSF Live Load					
				L/360			L/480			L/360			L/480			L/360			L/480			L/360			L/480			L/360			L/480								
Web	Gauge	Flange	Lip	SINGLE SPAN JOIST SPACING (IN.) O.C.			SINGLE SPAN JOIST SPACING (IN.) O.C.			SINGLE SPAN JOIST SPACING (IN.) O.C.			SINGLE SPAN JOIST SPACING (IN.) O.C.			SINGLE SPAN JOIST SPACING (IN.) O.C.			SINGLE SPAN JOIST SPACING (IN.) O.C.			SINGLE SPAN JOIST SPACING (IN.) O.C.			SINGLE SPAN JOIST SPACING (IN.) O.C.			SINGLE SPAN JOIST SPACING (IN.) O.C.											
				(in)	(in)	(in)	12	16	24	12	16	24	12	16	24	12	16	24	12	16	24	12	16	24	12	16	24	12	16	24	12	16	24						
12	16	2	0.5	24'5"	21'1"	17'3"	24'5"	21'1"	17'3"	20'7"	17'10"	14'7"	20'7"	17'10"	14'7"	19'3"	16'8"	13'7"	19'3"	16'8"	13'7"	17'3"	14'11"	12'2"	17'3"	14'11"	12'2"	14'7"	12'7"	9'10"	14'7"	12'7"	9'10"	13'5"	11'7"	8'4"	13'5"	11'7"	8'4"
12	14	2	0.5	28'4"	24'9"	20'3"	25'9"	23'4"	20'3"	24'2"	20'11"	17'1"	22'6"	20'5"	17'1"	22'7"	18'7"	16'0"	22'7"	18'7"	16'0"	20'3"	17'6"	14'3"	20'3"	17'6"	14'3"	17'1"	14'9"	12'1"	17'1"	14'9"	12'1"	15'9"	13'7"	11'1"	15'9"	13'7"	11'1"
12	12	2	0.5	31'10"	28'11"	25'0"	28'11"	26'3"	22'11"	27'10"	25'3"	21'2"	25'3"	22'11"	20'1"	28'10"	24'3"	19'9"	28'0"	24'3"	19'9"	25'0"	21'8"	17'8"	25'0"	21'8"	17'8"	21'2"	18'4"	14'11"	19'9"	18'0"	14'11"	19'6"	16'10"	13'9"	19'6"	16'10"	13'9"
12	10	2	0.5	33'9"	30'8"	26'10"	30'8"	27'10"	24'4"	29'6"	26'10"	23'5"	26'10"	24'4"	21'3"	30'8"	26'11"	22'0"	30'8"	26'11"	22'0"	27'10"	24'1"	19'8"	26'10"	24'1"	19'8"	23'1"	20'4"	16'7"	21'0"	19'1"	16'7"	21'8"	18'9"	15'4"	21'0"	18'9"	15'4"
12	16	2	0.625	25'3"	21'10"	17'10"	23'10"	21'8"	17'10"	21'4"	18'6"	15'1"	20'10"	18'6"	15'1"	19'11"	17'3"	14'1"	19'11"	17'3"	14'1"	17'10"	15'5"	12'7"	17'10"	15'5"	12'7"	15'1"	13'0"	9'10"	15'1"	13'0"	9'10"	13'10"	12'0"	8'4"	13'10"	12'0"	8'4"
12	14	2	0.625	28'7"	25'2"	20'6"	25'11"	23'7"	20'6"	24'7"	21'3"	17'4"	22'8"	20'7"	17'4"	23'0"	19'11"	16'3"	23'0"	19'11"	16'3"	20'6"	17'9"	14'6"	20'6"	17'9"	14'6"	17'4"	15'0"	12'3"	17'4"	15'0"	12'3"	16'0"	13'10"	11'3"	16'0"	13'10"	11'3"
12	12	2	0.625	32'1"	29'2"	25'4"	29'2"	26'6"	23'2"	28'1"	25'6"	21'5"	25'6"	23'2"	20'3"	28'4"	24'7"	20'1"	28'4"	24'7"	20'1"	25'4"	22'0"	17'11"	25'4"	22'0"	17'11"	21'5"	18'7"	15'2"	19'11"	18'1"	15'2"	19'9"	17'1"	13'11"	19'9"	17'1"	13'11"
12	10	2	0.625	34'1"	30'11"	27'0"	30'11"	28'1"	24'7"	29'9"	27'0"	23'7"	27'0"	24'7"	21'5"	30'11"	27'3"	22'3"	30'11"	27'3"	22'3"	28'2"	24'5"	19'11"	27'0"	24'5"	19'11"	23'3"	20'7"	16'10"	21'2"	19'3"	16'9"	21'11"	19'0"	15'6"	21'2"	19'0"	15'6"
14	16	2	0.5	26'6"	22'11"	18'9"	26'6"	22'11"	18'9"	22'5"	19'5"	15'10"	22'5"	19'5"	15'10"	20'11"	18'2"	14'8"	20'11"	18'2"	14'8"	18'9"	16'3"	11'9"	18'9"	16'3"	11'9"	15'10"	12'7"	8'4"	15'10"	12'7"	8'4"	14'3"	10'8"	7'1"	14'3"	10'8"	7'1"
14	14	2	0.5	31'2"	27'0"	22'0"	29'0"	26'4"	22'0"	26'4"	22'10"	18'7"	25'4"	22'10"	18'7"	24'8"	21'4"	17'5"	24'8"	21'4"	17'5"	22'0"	19'1"	15'7"	22'10"	19'1"	15'7"	18'7"	16'1"	13'2"	18'7"	16'1"	13'2"	17'2"	14'10"	12'1"	17'2"	14'10"	12'1"
14	12	2	0.5	36'3"	32'11"	27'6"	32'11"	29'11"	26'1"	31'8"	28'6"	23'3"	28'9"	26'1"	22'10"	30'9"	26'8"	21'9"	30'9"	26'8"	21'9"	27'6"	23'10"	19'5"	27'6"	23'10"	19'5"	23'3"	20'2"	16'5"	22'6"	20'2"	16'5"	21'5"	18'7"	15'2"	21'5"	18'7"	15'2"
14	10	2	0.5	38'6"	35'0"	30'6"	35'0"	31'9"	27'9"	33'7"	30'6"	26'2"	30'6"	27'9"	24'3"	34'7"	29'11"	24'5"	34'7"	29'11"	24'5"	30'11"	26'9"	21'10"	30'6"	26'9"	21'10"	26'2"	22'8"	18'6"	23'11"	21'9"	18'6"	24'1"	20'10"	17'0"	23'11"	20'10"	17'0"
14	16	2	0.625	27'5"	23'9"	19'5"	26'10"	23'9"	19'5"	23'2"	20'1"	16'5"	23'2"	20'1"	16'5"	21'8"	18'9"	14'8"	21'8"	18'9"	14'8"	19'5"	16'9"	11'9"	19'5"	16'9"	11'9"	16'5"	12'7"	8'4"	16'5"	12'7"	8'4"	14'3"	10'8"	7'1"	14'3"	10'8"	7'1"
14	14	2	0.625	31'8"	27'5"	22'5"	29'3"	26'7"	22'5"	26'9"	23'2"	18'11"	25'7"	23'2"	18'11"	25'1"	21'8"	17'8"	25'1"	21'8"	17'8"	22'5"	19'5"	15'10"	22'5"	19'5"	15'10"	18'11"	16'5"	13'4"	18'11"	16'5"	13'4"	17'5"	15'1"	12'4"	17'5"	15'1"	12'4"
14	12	2	0.625	36'6"	33'2"	27'11"	33'2"	30'2"	26'4"	31'11"	28'10"	23'7"	29'0"	26'4"	23'0"	31'2"	27'0"	22'0"	31'2"	27'0"	22'0"	27'11"	24'2"	19'8"	27'11"	24'2"	19'8"	23'7"	20'5"	16'8"	22'8"	20'5"	16'8"	21'8"	18'9"	15'4"	21'8"	18'9"	15'4"
14	10	2	0.625	38'10"	35'3"	30'9"	35'3"	32'0"	28'0"	33'11"	30'9"	26'6"	30'9"	28'0"	24'5"	35'0"	30'4"	24'9"	35'0"	30'4"	24'9"	31'4"	27'1"	22'2"	30'9"	27'1"	22'2"	26'6"	22'11"	18'8"	24'1"	21'11"	18'8"	24'4"	21'1"	17'3"	24'1"	21'1"	17'3"

Structural

Structural